



# Heyco® "Female Bridge" Preassembled Cordset Components

## NEMA 5-15R

- Crimp all three terminals at once.
- Faster loading of plug molds.
- Automated terminating equipment is available, see page 7-11.
- Reduces plug molding cycle time.
- Assures reliable contact performance.
- Passes UL/CSA cold temperature insertion test.
- Improves plug quality.
- Reduces PVC usage and plug cost!
- Eliminates the need for a polarity barrier.

PART NO.	DESCRIPTION	WIRE RANGE	DIE	CRIMP PUNCH	ANVIL
S7570	5-15R Female Bridge Assembly Black	18-12 AWG	Z370	Z335, Z409	Z334
S7571	5-15R Female Bridge Assembly Natural	18-12 AWG	Z370	Z335, Z409	Z334
S7572	5-15R Female Bridge Assembly Black	12-10 AWG	Z641	Z636, Z637	Z635
S7573	5-15R Female Bridge Assembly Natural	12-10 AWG	Z641	Z636, Z637	Z635

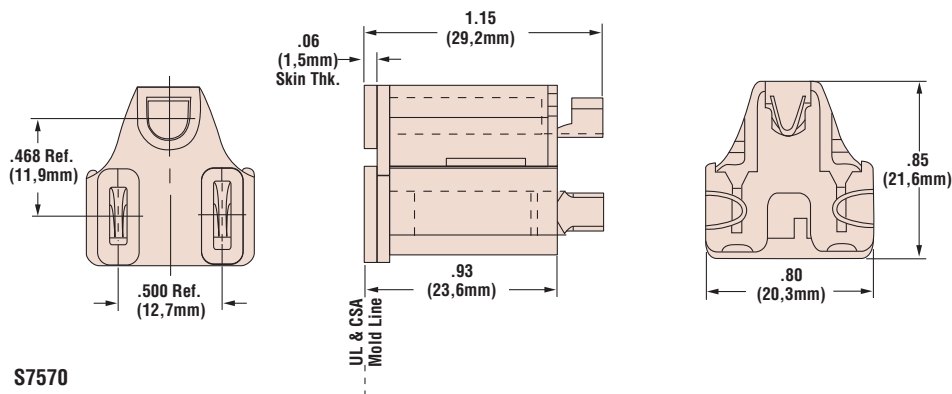

S7570



# Heyco® IEC 320 Preassembled Cordset Components

- Crimp all three terminals at once.
- Faster loading of plug molds.
- Automated terminating equipment is available. Consult Heyco for details.
- Assures reliable contact performance.
- Improves plug quality.
- Reduces PVC usage and plug cost.
- Available assembled or unassembled.

PART NO.	DESCRIPTION	WIRE RANGE	DIE	CRIMP PUNCH	ANVIL
S7580	IEC 320 Biz. Machine Assembly Black	18-14 (AWG)	S7580SXX5	C774	C775
S7780	Unassembled IEC-320 Housing Black	—	—	—	—
S7200	Unassembled BMC IEC-320 Contact	18-14 (AWG)	S7200UXX5 S7200SXX5	C688	C689

