

# Heyco® Preassembled Cordset Components

## Tri-Tap Premold

- Multiple piece unit that reduces the number of crimp connections on an extension cord from 9 down to 3. Now you can crimp all 3 terminals at once.
- Significantly reduces the amount of material required for overmolding, substantially reducing the cycle time and cost.
- Available in assembled or component form.
- Terminating equipment is available. See page 7-11.
- **Heyco Contacts MUST be used in Heyco pre-molds.**

### Components For Tri-Tap Premold

• **S7400**

- 0387 Premold Body
- 0388 Premold Cover
- 8075 T-tap Blade
- 8076 T-tap Blade
- 8087 T-tap Ground

• **S7403**

- 0387 Premold Body
- 0388 Premold Cover
- 8077 T-tap Blade (18-14 AWG)
- 8078 T-tap Blade (18-14 AWG)
- 8092 T-tap Ground (18-14 AWG)

PART NO.	DESCRIPTION	WIRE RANGE	DIE	CRIMP PUNCH	ANVIL
S7400	Female Receptacle Black	14-10 AWG	S7400SXX5	C856, C857	C851
S7403	Female Receptacle Black	18-14 AWG	S7403SXX5	C862, C863	C851

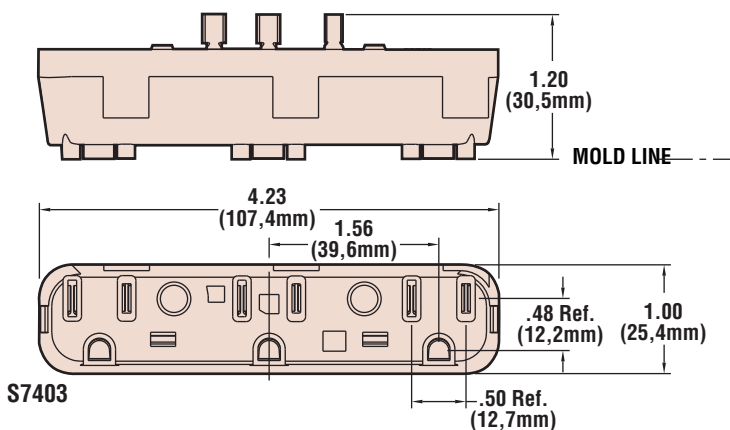
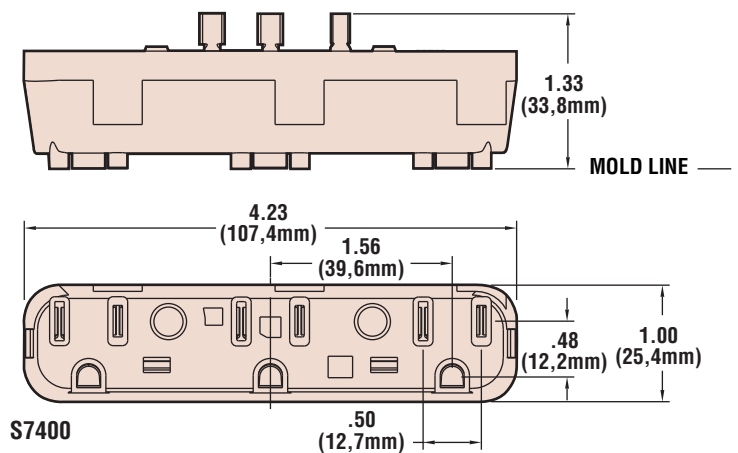

Quick Specs

Material	6/6 Nylon
Rating	125 Volts, 15 amps